

# Datasheet

## VSN-RP1r-Plus2 1 Risk Extinguishing Gas Control Panel



### Product Overview

The VSN-RP1r-Plus2 gas control panel has been designed to efficiently manage the automatic release sequence of any extinguishing system of gas, CO<sub>2</sub> (according to EN12094:1/2003 requirements), foam, dust, aerosols or sprinklers.

The VSN-RP1r-Plus2 compact control panel includes: a switched 65W power supply with battery charger; three input zones to connect directly to two-wire conventional detectors and external release call point; two monitored and electronically protected output circuits and two sounder outputs with different frequencies to identify each of the extinguishing stages (preactivated mode, activated mode, hold/abort and soak).

The front panel includes 44 status leds, 2-digit countdown timer, a GAS sign and a keyswitch for keyboard access.

There are circuits for low and flow pressure monitoring and open door control; input circuits for hold and release abort call points and seven status relays (preactivated, activated and extinguishing release in process, general fault output and operating mode: disabled, manual or automatic).

The VSN-RP1r-Plus2 provides two RS232 serial ports, a USB port and a I2C bus for remote system monitoring, connection to a TG graphic software and event log visualization.

### Features

- Compact extinguishing control panel with 32 bits microprocessor.
- 3 conventional zones: 2 for detectors and a third one which can be configured for detectors or call points.
- Inputs for abort and gas release call points and hold pushbutton.
- Release delay which can be configured from 0 to 60 sec. and verification time (before activating the sounders) from 0 to 10 min.
- Delays can be disabled from the keyboard (optional).
- Input circuits for flow and low pressure and open door monitoring.
- Two release circuits. The second one can be used independently for preactivation.
- Countdown timer display which indicates the seconds left for release.
- 44 status leds to quickly identify events.
- 7 relays for status indication and operating mode.
- Operating mode: Automatic, Manual and Disabled.
- Digital input for remote action such as: system reset, evacuation, silence or delay on/off.
- Plug-in terminals for all connections.
- Software for status visualization from the PC with remote connection option.
- Certified according to EN54-2/4:A2/2006 and EN12094/1:2003.

## Accessories

TFT-SUPRA	4.3" (480x272 pixels) graphic display for RP1r control panels
RP1r-RPT	Remote repeater via VSN-485 of the status and function keys of the RP1r. Requires 24Vdc.
VSN-485	RS485 communications board to connect the RP1R-RPT repeater or RP1R-PAN-V annunciator up to 1,200 meters (4,000 feet)
VSN-232	Board with one RS232 communications port. It is supplied with PK-RP1r software to display the control panel status from PC and diagnostics. It is installed inside the RP1r control panel.
VSN-4REL	4 NO/NC relay board. Each relay can be configured independently and linked to the 12 activation matrices. It is installed inside the RP1r control panel.
TG-IP1-SEC	Device to redirect the RS232 serial port, from the control panel to the TG graphic management software, through the IP protocol. Compatible with Ethernet networks at 10 and 100Mhz.
TG-C	License for Honeywell TG software, allows the graphic management of the control panels. It also allows to reset, silence sounders, disable/enable the 3 zones, know the status of all inputs of the extinguishing control panel displaying the keypad on the screen of the RP1r control panel. Requires physical key TG-BASE.
RP1R-PAN-V	Event annunciator with customized voice and written messages for RP1r extinguishing systems.

## Technical specifications

Electrical specifications	
Power supply:	90 - 264Vac; 50/60Hz.
Standby current:	125mA max.
Total max. current:	2.4Amp
Batteries:	2 x 7A/h
Battery load current:	300mA max.
Battery fuse:	F4AL 250V (4Amp)
2 monitored sounder outputs:	2 x 250mA
2 aux. power supply outputs:	2 x 250mA (resettable and non-resettable)
2 release circuits:	1Amp max. each circuit

## Environmental specifications

Operating temperature:	-5°C to +40°C
Operating humidity:	95% max. RH
Panel sealing:	IP30
Mechanical specifications	
Dimensions in mm:	381 (W) x 353 (H) x 123 (D)
Weight (without/with batteries):	4 Kg / 9.3 Kg
Plug-in Terminals:	2,5 mm <sup>2</sup> max.
Colour:	RAL 7021
Material:	ABS V0
<b>Designed in compliance with:</b>	EN54-2/4:A2/2006 & EN12094/1:2003
CPD Certificate:	1134-CPD-045

## General wiring diagram

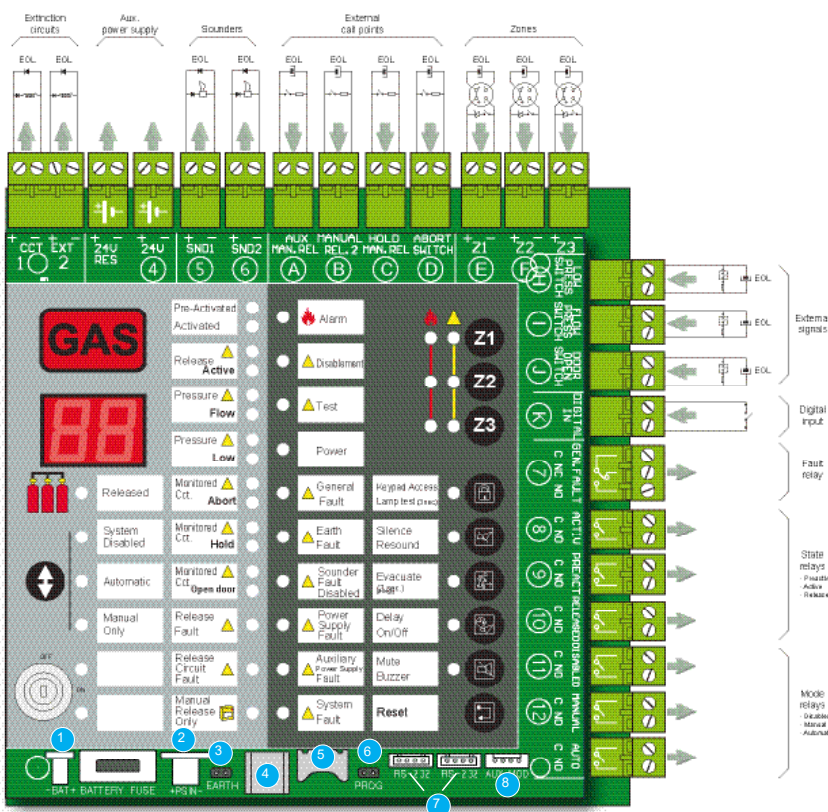

- 1 Battery connection
- 2 Power supply connector
- 3 Inhibition monitoring earth jumper
- 4 USB port
- 5 Lithium battery location
- 6 Access level 3 jumper
- 7 RS-232 communication port
- 8 I<sup>2</sup>C auxiliary communication port



Honeywell Life Safety  
Austria GmbH  
Technologiestr. 5  
A-1120 Vienna, Austria  
T: +43 1 600 60 30  
[www.hls-austria.com](http://www.hls-austria.com)